

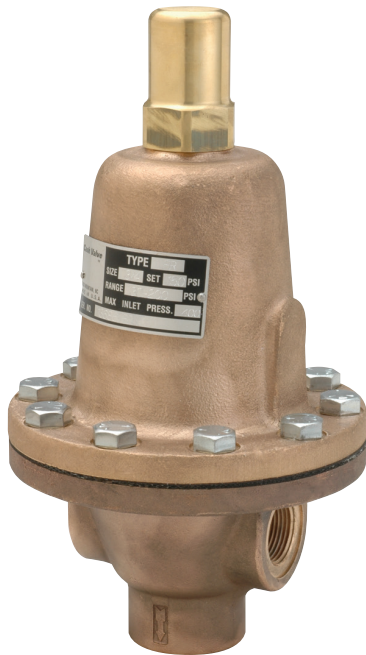

CASH VALVE™ FR SERIES BACK PRESSURE VALVES

Diaphragm actuated valves designed for either continuous or intermittent operation which provide accurate, repetitive pressure control.



FEATURES

- Protect against periodic high pressure, control dependably at adjusted pressures and shut tight.
- Maintain a pre-determined pressure on the inlet regardless of variations in pressure at the outlet.
- Unique full 'floating ring' seating arrangement provides smooth, even control in response to pressure changes.
- Globe type body with two side inlets and a bottom outlet, suitable for angle or in-line installation.
- Types FR and FR-6 fitted with a closing cap to discourage unauthorized tampering.
- Optional differential pressure control modification enables a constantly held difference between reference and valve inlet pressures.
- Type FR-6 incorporates a diaphragm ring above the diaphragm for higher back pressure ranges.
- Rugged, simple design enables easy on-line maintenance and repair.
- Optional cryogenic service construction available for handling cold fluids to -320°F (-195°C).

GENERAL APPLICATION

For use on practically all fluids and gases except steam, these valves are especially suited for all grades of oils, including Bunker 'C', and may be used in centrifugal, regenerative turbine, reciprocating or rotary pump bypass valve applications.

TECHNICAL DATA⁽¹⁾

Materials:	Bronze, brass, carbon steel, cast iron, stainless steel
Sizes:	¼ to 2 in. (8 to 50 mm)
Connections:	NPTF, BSPT
Pressure range:	0 to 600 psig (0 to 41.4 barg)
Temperature range:	-40 to 450°F (-40 to 232°C)

1. Refer to General Specifications Table in page 2 for more information.

CASH VALVE™ FR SERIES BACK PRESSURE VALVES

GENERAL SPECIFICATIONS

Product	Body Material	Spring Chamber Material	Service	Body Size, in. (mm)	Materials		Maximum Inlet Pressure, psi (bar)	Maximum Outlet Pressure, psi (bar)	Temperature, °F (°C)
					Diaphragm	O-ring			
FR	Bronze, 316 SST, Steel or Iron	Bronze, 316 SST, Steel or Iron	Water/Air, Oil/Gases	½ to 2 (15 to 50)	Bronze, Monel® or 316 SST	PTFE	400 (27.6)	400 (27.6)	-40 to 450 [-40 to 232]
						NBR or FKM	400 (27.6)	400 (27.6)	-40 to 180 [-40 to 82]
					NBR, FKM or NBR with PTFE Liner	----	400 (27.6)	400 (27.6)	-40 to 180 [-40 to 82]
FR-6	Bronze or 316 SST	Bronze or 316 SST	Water/Air, Oil/Gases	½ to 2 (15 to 50)	Bronze, Monel® or 316 SST	PTFE	600 (41.4)	600 (41.4)	-40 to 450 [-40 to 232]
						NBR or FKM	600 (41.4)	600 (41.4)	-40 to 180 [-40 to 82]
					NBR or NBR with PTFE Liner	----	600 (41.4)	600 (41.4)	-40 to 180 [-40 to 82]
FR-10	Iron	Iron	Water/Air, Oil/Gases	½ to 2 (15 to 50)	Monel®	PTFE	250 (17.2)	250 (17.2)	-40 to 180 [-40 to 82]
						NBR or FKM	250 (17.2)	250 (17.2)	-40 to 180 [-40 to 82]
					NBR or FKM	----	250 (17.2)	250 (17.2)	-40 to 180 [-40 to 82]
FRM	Brass or 316 SST	Brass or Aluminum	Water/Air, Oil/Gases	¼ and ⅜ (8 and 10)	Bronze	----	600 (41.4)	600 (41.4)	-40 to 400 [-40 to 204]
					316 SST	----	600 (41.4)	600 (41.4)	-40 to 400 [-40 to 204]
					NBR	----	600 (41.4)	600 (41.4)	-40 to 180 [-40 to 82]
					Neoprene	----	600 (41.4)	600 (41.4)	-40 to 180 [-40 to 82]
FRM-2	Brass or 316 SST	Brass	Water/Air, Oil/Gases	¼ to ½ (8 to 15)	Bronze	----	600 (41.4)	600 (41.4)	-40 to 400 [-40 to 204]
					316 SST	----	600 (41.4)	600 (41.4)	-40 to 400 [-40 to 204]
					NBR	----	600 (41.4)	600 (41.4)	-40 to 180 [-40 to 82]
					FKM	----	600 (41.4)	600 (41.4)	-40 to 180 [-40 to 82]
					Neoprene	----	600 (41.4)	600 (41.4)	-40 to 180 [-40 to 82]

Monel® is a mark owned by Special Metals Corporation.

CASH VALVE™ FR SERIES BACK PRESSURE VALVES

TYPES FR, FR-6, FR-10 OVERVIEW

When sized correctly, these valves will both open and close at predetermined points to provide accurate functional control for the continuous protection of pumps, process piping systems and similar equipment. They are not emergency devices, but are continuously operating valves which provide accurate, repetitive pressure control.

Sizes: ½, ¾, 1, 1 ¼, 1 ½ and 2 in. (15, 20, 25, 32, 40 and 50 mm).

FR Series valves are available in various pressure control and temperature ranges and are designated as follows:

- Type FR has a bronze body as standard, is suitable for pressures of 0 to 400 psig (0 to 27.6 barg) and maximum temperatures 180 to 450°F (82 to 232°C).
- Type FR-6 incorporates a diaphragm ring mounted above the diaphragm to accommodate higher back pressure ranges: 200 to 600 psig (13.8 to 41.4 barg); 180 to 450°F (82 to 232°C).
- The Type FR-10 is for more economical, lower pressure applications and is fitted with an iron body and spring chamber: 0 to 250 psig (0 to 17.2 barg); 180°F (82°C).

OPERATION

In a typical installation, inlet pressure enters from the side of the valve and registers under the diaphragm. When pressure rises above the set point of the valve, the diaphragm moves upward - away from the seat - allowing flow to pass through the bottom port. When inlet pressure drops below the setting of the valve, the diaphragm moves downward to the closed position.

UNIQUE 'FLOATING RING' SEATING DESIGN

The valves' 'floating ring' principle compensates completely for unavoidable misalignment, producing perfect seat contact, free to move laterally in any direction to find its own correct alignment with the spherical seat disc.

It is thoroughly tested and proven to give far superior performance than ordinary valves using pistons and cylinders where good seat alignment is next to impossible. The diaphragm and seat disc are fastened together securely resulting in positive and rapid seat movement in response to all pressure changes.

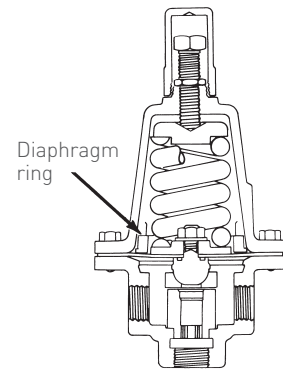

TYPE FR-6 INTERIOR VIEW

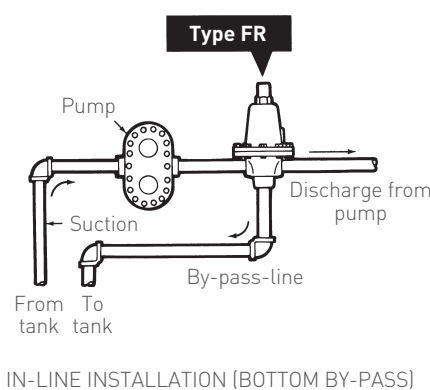
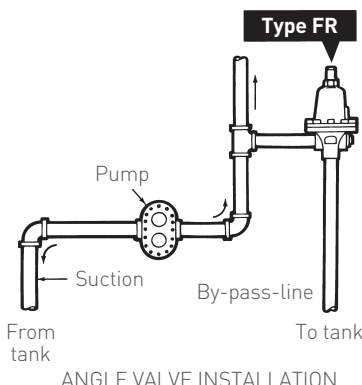
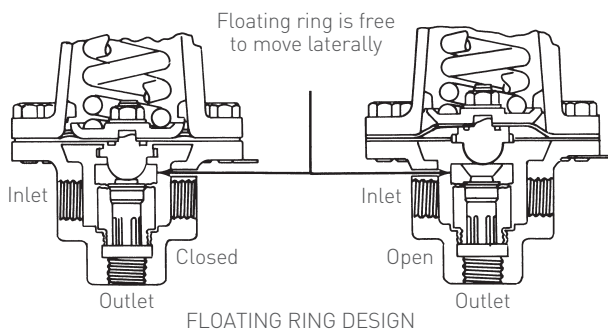

CASH VALVE™ FR SERIES BACK PRESSURE VALVES

TYPES FR, FR-6, FR-10 CONSTRUCTION/SPECIFICATIONS

FR Series back pressure valves incorporate an iron or bronze body (iron standard for Type FR-10; carbon steel or stainless steel may be fitted to Types FR and FR-6 on special order) with threaded connections; bronze, stainless steel, Monel®, Fluorocarbon (FKM) or Nitrile (NBR) diaphragm; brass or stainless steel body seat, with a renewable stainless seat disc and seat ring.

TYPES FR, FR-6, FR-10

Valve size, in. (mm)	Dimensions, in. (mm)					Shipping weight, lbs (kg)		
	A	B	C	D	E	Iron	Bronze	Iron (FR-10)
½ (15) ¹⁾	4.75 (121)	6.88 (175)	1.62 (41.4)	1.44 (36.6)	2.88 (73.2)	8 (3.63)	9 ½ (4.31)	7 (3.18)
¾ (20)	5.63 (143)	7.97 (202)	2.00 (50.8)	1.69 (42.9)	3.38 (85.9)	13 (5.90)	14 ¾ (6.69)	11 ½ (5.22)
1 (25)	6.50 (165)	10.31 (262)	2.25 (57.2)	2.13 (54.1)	4.25 (108)	20 ¼ (9.19)	23 ½ (10.7)	18 ¼ (8.28)
1 ¼ (32)	6.50 (165)	10.44 (265)	2.38 (60.5)	2.13 (54.1)	4.25 (108)	21 ½ (9.75)	24 ½ (11.1)	19 ½ (8.85)
1 ½ (40)	7.50 (191)	10.81 (275)	2.63 (66.8)	2.50 (63.5)	5.00 (127)	29 (13.1)	33 (15.0)	27 (12.2)
2 (50)	7.50 (191)	11.06 (281)	3.00 (76.2)	2.50 (63.5)	5.00 (127)	31 ½ (14.3)	35 ½ (16.1)	29 ½ (13.4)

1. ½ in. (15 mm) Type FR only UL approved in iron body and metal diaphragm up to 150 psi (10.3 bar).

Important: All Types FR, FR-6 and FR-10 are furnished with a travel stop that prevents diaphragms from extending beyond their limit.

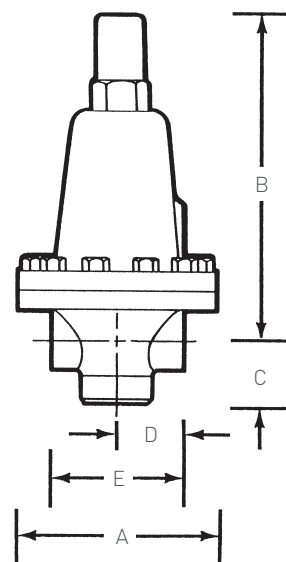

TYPE FR

Monel® is a mark owned by Special Metals Corporation.

CASH VALVE™ FR SERIES BACK PRESSURE VALVES

TYPES FRM, FRM-2 OVERVIEW

Types FRM and FRM-2 function as automatic pressure limiting regulators, maintaining a desired maximum pressure in a system or vessel by relieving excess pressure. They are small and compact, yet are highly efficient, making them suitable for numerous applications that call for a small accurate back pressure regulator for service on liquids, air and gases not corrosive to brass. Furnished with either bronze, stainless steel, NBR or neoprene diaphragms in three body styles.

Sizes: 1/4, 3/8 and 1/2 in. (8, 10 and 15 mm).

Maximum temperature:

- with NBR or neoprene diaphragm: 180°F (82°C).
- with Bronze or stainless steel diaphragm: 500°F (260°C).

- Type FRM-2 is designed with larger physical dimensions and internal seat opening providing greater capacity. It is also suitable for fuel oils and lube oils and is available in stainless steel body with system exposed internal parts for service with corrosive or harsh fluids.
- Types FRM and FRM-2 incorporate the same superior 'floating ring' design as the larger Type FR to provide smooth, even pressure control.
- Optional cryogenic service construction is offered for the FRM and FRM-2 to enable them to be used for oxygen service suitable for temperatures to -320°F (-195°C).
- All versions fitted with adjusting screw as standard. Also available with T-handle and with bushing for mounting the valve to a control panel, on special order.
- All valves are furnished with a travel stop that prevents diaphragms from extending beyond their limit.



TYPE FRM



TYPE FRM-2

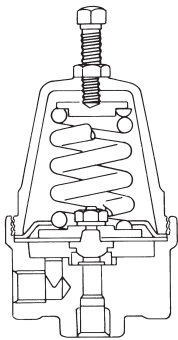

TYPE FRM-2
SIDE INLET - BOTTOM OUTLET

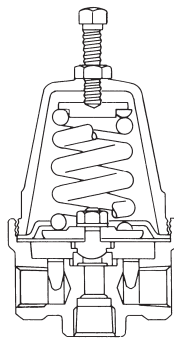

TYPE FRM-2
TWO SIDE INLET - BOTTOM OUTLET

CASH VALVE™ FR SERIES BACK PRESSURE VALVES

TYPES FRM, FRM-2 CONSTRUCTION/SPECIFICATIONS

FRM Series are diaphragm-type miniature back pressure valves fitted with forged brass bodies, brass or aluminum (Type FRM only) spring chambers and neoprene or bronze diaphragms.

TYPES FRM, FRM-2 DIAPHRAGM MINIATURE BACK PRESSURE VALVES

Type	Valve size, in. (mm)	Relief pressure range, psi (bar)	Valve connections ^[2]		
			S.I.-S.O.	S.I.-B.O.	2S.I.-B.O.
FRM	¼, ⅜ (8, 10)	0 to 600 (0 to 41.4)	×	×	×
FRM-2 ^[1]	¼, ⅜, ½ (8, 10, 15)	0 to 600 (0 to 41.4)	×	×	×

- The Type FRM-2 is UL approved in all sizes and body styles with metal diaphragms up to 150 psi (10.3 bar).
- Abbreviations used above are to be read as follows: S.I. = Side Inlet; 2S.I. = Two Side Inlets; S.O. = Side Outlet; B.O. = Bottom Outlet

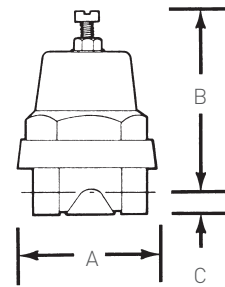

TYPE FRM

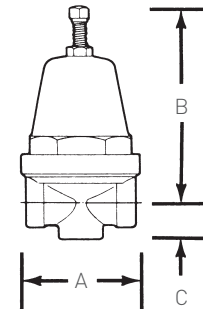

TYPE FRM-2

Type	Valve size, in. (mm)	Dimensions, in. (mm)			Shipping weight, lbs (kg)
		A	B	C	
FRM	¼ (8)	2.30 (58.3)	3.19 (81.1)	0.44 (11.1)	1 ½ (0.51)
FRM	⅜ (10)	2.30 (58.3)	3.19 (81.1)	0.44 (11.1)	1 ½ (0.51)
FRM-2	¼ (8)	2.88 (73.2)	4.50 (114)	1.00 (25.4)	2 ½ (1.13)
FRM-2	⅜ (10)	2.69 (68.3)	4.50 (114)	0.75 (19.1)	2 ½ (1.13)
FRM-2	½ (15)	2.96 (75.2)	4.59 (117)	1.13 (28.7)	3 ½ (1.59)

CAPACITY INFORMATION

The capacity charts for water are based on the specific gravity reading of water. If a liquid with a specific gravity other than that of water is being used in the system, it is necessary to apply a correction factor. For example, if a fluid to be used has a specific gravity reading of 1.5 and the given flow is 40 gpm: Refer to the specific gravity graph and find 1.5 on the vertical axis then read across to the diagonal intersect to obtain a S.G. factor of .8. Divide the given flow (40 gpm) by the 0.8 factor and obtain 50 gpm, the corrected flow for the fluid being used. Refer to the capacity charts to determine the correct valve size that should be used at the desired set pressure and at the corrected flow.

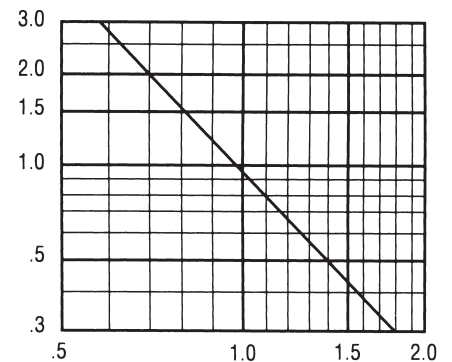

CASH VALVE™ FR SERIES BACK PRESSURE VALVES

TYPES FR, FR-6, FR-10 WATER CAPACITY (gpm)

				Inlet size ½ in. (15 mm)					
Types			Set pressure ^[1] , psig	Rubber diaphragm			Metal diaphragm		
FR	FR-6	FR-10		10% Rise	20% Rise	30% Rise	10% Rise	20% Rise	30% Rise
X		X	10 ^[2]	2.0	4.0	6.0	1.0	1.5	3.0
X		X	15	2.2	4.2	6.5	1.2	2.0	3.5
X		X	20	2.5	4.5	7.5	1.4	2.5	4.0
X		X	30	3.0	5.0	9.0	1.7	3.0	5.0
X		X	40	3.5	6.0	9.7	2.0	3.5	6.0
X		X	50	3.7	6.5	10.5	2.2	4.0	7.0
X		X	75	4.5	7.5	13.0	2.6	5.0	8.0
X		X	100	5.0	9.5	16.0	3.0	6.0	10.0
X		X	150	7.0	11.5	19.0	3.5	8.0	13.0
X	X	X	200	8.0	15.0	22.0	4.5	10.0	17.0
X	X		300	12.0	19.0	25.0	7.5	15.0	22.0
X	X		400	18.0	24.0	25.0	12.0	23.0	25.0
	X		600	21.0	25.0	25.0	16.0	25.0	25.0

TYPES FR, FR-6, FR-10 WATER CAPACITY (gpm) (CONTINUED)

				Inlet size ¾ in. (20 mm)					
Types			Set pressure ^[1] , psig	Rubber diaphragm			Metal diaphragm		
FR	FR-6	FR-10		10% Rise	20% Rise	30% Rise	10% Rise	20% Rise	30% Rise
X		X	10 ^[2]	3.0	6.0	8.0	1.8	3.5	5.5
X		X	15	3.2	6.2	8.5	2.0	4.5	6.5
X		X	20	3.5	6.7	10.0	2.5	5.0	7.5
X		X	30	4.0	7.2	11.5	3.0	6.0	9.5
X		X	40	4.5	8.5	12.5	3.5	7.0	11.0
X		X	50	4.7	9.5	14.5	4.0	8.0	12.0
X		X	75	5.5	11.5	17.0	5.0	10.0	14.0
X		X	100	6.0	14.0	21.0	6.0	11.0	16.0
X		X	150	9.0	18.0	25.0	7.0	15.0	20.0
X	X	X	200	11.0	21.5	30.0	9.0	17.0	24.0
X	X		300	16.0	26.5	30.0	13.0	20.0	28.0
X	X		400	23.0	30.0	30.0	17.0	28.0	30.0
	X		600	30.0	30.0	30.0	20.0	30.0	30.0

TYPES FR, FR-6, FR-10 WATER CAPACITY (gpm) (CONTINUED)

				Inlet size 1 in. (25 mm)					
Types			Set pressure ^[1] , psig	Rubber diaphragm			Metal diaphragm		
FR	FR-6	FR-10		10% Rise	20% Rise	30% Rise	10% Rise	20% Rise	30% Rise
X		X	10 ^[2]	4.0	8.0	14.0	2.5	5.5	7.8
X		X	15	5.0	10.0	17.0	3.0	6.5	9.5
X		X	20	6.0	12.0	20.0	3.5	7.5	11.0
X		X	30	7.5	14.0	23.0	4.0	9.0	13.0
X		X	40	9.0	16.0	26.0	5.0	10.5	15.0
X		X	50	10.0	18.0	30.0	5.5	12.0	17.0
X		X	75	12.0	20.0	38.0	6.5	14.5	20.0
X		X	100	14.5	27.0	46.0	7.5	17.0	24.0
X		X	150	17.0	33.0	54.0	9.0	21.0	30.0
X	X	X	200	22.5	41.0	54.0	11.0	24.0	33.0
X	X		300	27.0	54.0	54.0	15.0	29.0	42.0
X	X		400	34.0	54.0	54.0	20.0	34.0	54.0
	X		600	54.0	54.0	54.0	24.0	50.0	54.0

NOTES

1. Set pressures are based upon valve discharge into an atmospheric pressure return line. If return line pressure is significantly higher than atmospheric pressure, then consult factory for capacity information.
2. For set pressures less than 10 psi (0.69 bar) consult the factory.

CASH VALVE™ FR SERIES BACK PRESSURE VALVES

TYPES FR, FR-6, FR-10 WATER CAPACITY (gpm) (CONTINUED)

Types				Inlet size 1 1/2 in. (32 mm)					
				Rubber diaphragm			Metal diaphragm		
FR	FR-6	FR-10	Set pressure ^[1] , psig	10% Rise	20% Rise	30% Rise	10% Rise	20% Rise	30% Rise
X		X	10 ^[2]	5.0	11.5	18.0	3.0	6.5	9.5
X		X	15	6.0	12.5	20.0	3.8	8.0	11.5
X		X	20	7.0	14.0	23.0	4.5	9.0	13.5
X		X	30	8.0	16.0	27.0	5.5	11.5	16.5
X		X	40	10.0	18.0	31.0	6.3	13.2	19.0
X		X	50	11.0	20.0	34.0	7.0	14.7	21.5
X		X	75	13.0	24.0	42.0	8.5	18.0	26.0
X		X	100	16.0	32.0	50.0	9.8	21.0	30.0
X		X	150	20.0	44.0	66.0	12.0	25.5	40.0
X	X	X	200	25.0	55.0	80.0	14.0	29.5	53.0
X	X		300	34.0	70.0	80.0	17.0	36.0	80.0
X	X		400	42.0	80.0	80.0	22.0	48.0	80.0
	X		600	65.0	80.0	80.0	44.0	80.0	80.0

TYPES FR, FR-6, FR-10 WATER CAPACITY (gpm) (CONTINUED)

Types				Inlet size 1 1/2 in. (40 mm)					
				Rubber diaphragm			Metal diaphragm		
FR	FR-6	FR-10	Set pressure ^[1] , psig	10% Rise	20% Rise	30% Rise	10% Rise	20% Rise	30% Rise
X		X	10 ^[2]	6.0	13.0	20.0	4.2	7.8	11.8
X		X	15	7.0	14.0	23.0	5.0	9.5	14.2
X		X	20	8.0	15.0	27.0	6.0	11.0	16.5
X		X	30	9.0	18.0	30.0	7.2	13.5	20.0
X		X	40	11.0	20.0	34.0	8.5	15.5	23.5
X		X	50	13.0	23.0	40.0	9.5	17.3	26.0
X		X	75	15.0	32.0	49.0	11.5	21.0	36.0
X		X	100	18.0	40.0	60.0	13.2	24.5	48.0
X		X	150	22.0	54.0	77.0	16.2	30.0	62.0
X	X	X	200	27.0	70.0	93.0	19.0	40.0	80.0
X	X		300	39.0	95.0	110.0	23.0	53.0	100.0
X	X		400	50.0	120.0	120.0	26.0	66.0	120.0
	X		600	80.0	120.0	120.0	50.0	80.0	120.0

TYPES FR, FR-6, FR-10 WATER CAPACITY (gpm) (CONTINUED)

Types				Inlet size 2 in. (50 mm)					
				Rubber diaphragm			Metal diaphragm		
FR	FR-6	FR-10	Set pressure ^[1] , psig	10% Rise	20% Rise	30% Rise	10% Rise	20% Rise	30% Rise
X		X	10 ^[2]	7	15	23	4.3	9.4	14.5
X		X	15	8	16	26	5.2	11.5	17.5
X		X	20	9	17	30	6.3	13.0	20.0
X		X	30	10	20	34	7.5	16.0	25.0
X		X	40	13	22	44	9.0	19.0	29.0
X		X	50	15	26	58	10.0	21.0	35.0
X		X	75	17	40	80	12.0	25.0	55.0
X		X	100	20	48	92	13.5	30.0	65.0
X		X	150	25	66	118	16.5	44.0	83.0
X	X	X	200	30	82	144	19.5	56.0	102.0
X	X		300	43	110	200	24.0	80.0	130.0
X	X		400	61	130	200	34.0	100.0	156.0
	X		600	108	162	200	64.0	136.0	200.0

NOTES

1. Set pressures are based upon valve discharge into an atmospheric pressure return line. If return line pressure is significantly higher than atmospheric pressure, then consult factory for capacity information.
2. For set pressures less than 10 psi (0.69 bar) consult the factory.

CASH VALVE™ FR SERIES BACK PRESSURE VALVES

TYPES FR, FR-6, FR-10 AIR CAPACITY (SCFM)

				Inlet size ½ in. (15 mm)					
Types			Set pressure ^[1] , psig	Rubber diaphragm			Metal diaphragm		
FR	FR-6	FR-10		10% Rise	20% Rise	30% Rise	10% Rise	20% Rise	30% Rise
X		X	10 ^[2]	7	15	22	3	7	10
X		X	15	8	17	30	4	9	14
X		X	20	10	19	38	5	10	16
X		X	30	13	24	48	7	13	20
X		X	40	16	34	56	8	17	25
X		X	50	19	44	72	10	19	34
X		X	75	30	56	90	11	23	44
X		X	100	40	74	108	12	32	60
X		X	150	60	104	150	14	46	84
X	X	X	200	92	140	200	16	60	120
X	X		300	140	210	300	22	90	160
X	X		400	180	280	400	35	120	240
	X		600	280	420	600	50	180	320

TYPES FR, FR-6, FR-10 AIR CAPACITY (SCFM) (CONTINUED)

				Inlet size ¾ in. (20 mm)					
Types			Set pressure ^[1] , psig	Rubber diaphragm			Metal diaphragm		
FR	FR-6	FR-10		10% Rise	20% Rise	30% Rise	10% Rise	20% Rise	30% Rise
X		X	10 ^[2]	10	24	30	6	12	19
X		X	15	15	30	48	8	15	24
X		X	20	20	38	62	10	18	32
X		X	30	25	48	80	12	22	42
X		X	40	31	62	120	15	25	50
X		X	50	38	74	150	20	30	58
X		X	75	48	86	225	25	36	63
X		X	100	60	96	300	32	50	80
X		X	150	86	144	440	40	72	120
X	X	X	200	128	180	600	46	100	160
X	X		300	190	270	850	54	145	240
X	X		400	240	360	1200	65	200	320
	X		600	380	540	1700	80	290	480

TYPES FR, FR-6, FR-10 AIR CAPACITY (SCFM) (CONTINUED)

				Inlet size 1 in. (25 mm)					
Types			Set pressure ^[1] , psig	Rubber diaphragm			Metal diaphragm		
FR	FR-6	FR-10		10% Rise	20% Rise	30% Rise	10% Rise	20% Rise	30% Rise
X		X	10 ^[2]	15	32	45	9	18	29
X		X	15	30	50	72	12	23	38
X		X	20	40	65	94	14	27	46
X		X	30	50	85	120	17	34	58
X		X	40	60	98	480	20	38	68
X		X	50	72	110	230	27	45	80
X		X	75	90	124	340	35	54	95
X		X	100	112	140	450	42	75	120
X		X	150	140	210	680	50	108	180
X	X	X	200	168	280	900	56	150	240
X	X		300	240	420	1250	66	215	360
X	X		400	320	560	1800	77	300	480
	X		600	480	820	2500	98	430	720

NOTES

- Set pressures are based upon valve discharge into an atmospheric pressure return line. If return line pressure is significantly higher than atmospheric pressure, then consult factory for capacity information.
- For set pressures less than 10 psi (0.69 bar) consult the factory.

CASH VALVE™ FR SERIES BACK PRESSURE VALVES

TYPES FR, FR-6, FR-10 AIR CAPACITY (SCFM) (CONTINUED)

				Inlet size 1½ in. (32 mm)					
Types			Set pressure ⁽¹⁾ , psig	Rubber diaphragm			Metal diaphragm		
FR	FR-6	FR-10		10% Rise	20% Rise	30% Rise	10% Rise	20% Rise	30% Rise
X		X	10**	22	40	60	11	22	35
X		X	15	38	60	90	15	29	56
X		X	20	48	80	134	22	35	76
X		X	30	60	128	172	28	45	90
X		X	40	72	148	190	32	60	96
X		X	50	82	166	250	36	66	102
X		X	75	106	185	375	42	78	120
X		X	100	130	225	500	50	96	180
X		X	150	160	275	750	58	120	240
X	X	X	200	200	350	1000	64	160	360
X	X		300	300	500	1450	82	250	480
X	X		400	400	700	1950	120	350	700
	X		600	600	1000	2850	160	500	950

TYPES FR, FR-6, FR-10 AIR CAPACITY (SCFM) (CONTINUED)

				Inlet size 1½ in. (40 mm)					
Types			Set pressure ⁽¹⁾ , psig	Rubber diaphragm			Metal diaphragm		
FR	FR-6	FR-10		10% Rise	20% Rise	30% Rise	10% Rise	20% Rise	30% Rise
X		X	10 ⁽²⁾	40	74	75	20	30	55
X		X	15	55	98	120	25	42	68
X		X	20	72	124	192	32	58	100
X		X	30	92	158	250	38	68	120
X		X	40	112	175	280	42	85	140
X		X	50	134	200	320	47	95	150
X		X	75	155	225	450	55	115	165
X		X	100	180	280	640	64	135	240
X		X	150	210	380	900	80	180	320
X	X	X	200	260	500	1250	100	250	480
X	X		300	400	700	1750	150	320	640
X	X		400	520	1000	2400	200	500	950
	X		600	800	1400	3450	300	650	1250

TYPES FR, FR-6, FR-10 AIR CAPACITY (SCFM) (CONTINUED)

				Inlet size 2 in. (50 mm)					
Types			Set pressure ⁽¹⁾ , psig	Rubber diaphragm			Metal diaphragm		
FR	FR-6	FR-10		10% Rise	20% Rise	30% Rise	10% Rise	20% Rise	30% Rise
X		X	10 ⁽²⁾	64	112	144	32	48	80
X		X	15	88	144	208	40	64	104
X		X	20	112	184	296	48	88	150
X		X	30	136	224	384	55	104	172
X		X	40	152	248	424	62	120	200
X		X	50	170	280	488	70	144	215
X		X	75	190	312	650	82	168	240
X		X	100	240	410	850	92	200	320
X		X	150	300	550	1100	120	272	475
X	X	X	200	400	750	1700	152	352	640
X	X		300	624	1050	2100	220	480	950
X	X		400	800	1500	3150	300	700	1250
	X		600	1200	2100	4000	400	960	1750

NOTES

1. Set pressures are based upon valve discharge into an atmospheric pressure return line. If return line pressure is significantly higher than atmospheric pressure, then consult factory for capacity information.
2. For set pressures less than 10 psi (0.69 bar) consult the factory.

CASH VALVE™ FR SERIES BACK PRESSURE VALVES

TYPE FRM WATER CAPACITY (GPM)

Set pressure ^[1] , psig	Inlet size ¼ in. (8 mm)				Inlet size ⅜ in. (10 mm)			
	Rubber diaphragm		Metal diaphragm		Rubber diaphragm		Metal diaphragm	
	10% Rise	20% Rise	10% Rise	20% Rise	10% Rise	20% Rise	10% Rise	20% Rise
10 ^[2]	0.2	0.7	0.1	0.5	0.2	0.7	0.1	0.5
25	0.5	1.2	0.5	1.0	0.5	1.2	0.5	1.0
50	1.2	2.5	0.7	1.7	1.2	2.5	0.7	1.7
100	2.1	3.5	1.4	3.0	2.1	3.5	1.4	3.0
150	2.5	4.8	1.5	4.0	2.5	4.8	1.5	4.0

TYPE FRM AIR CAPACITY (SCFM)

Set pressure ^[1] , psig	Inlet size ¼ in. (8 mm)				Inlet size ⅜ in. (10 mm)			
	Rubber diaphragm		Metal diaphragm		Rubber diaphragm		Metal diaphragm	
	10% Rise	20% Rise	10% Rise	20% Rise	10% Rise	20% Rise	10% Rise	20% Rise
10 ^[2]	0.5	1.5	0.3	0.9	0.5	1.5	0.3	0.9
25	2.1	6.5	1.2	4.0	2.1	6.5	1.2	4.0
50	5.0	16.0	2.6	9.5	5.0	16.0	2.6	9.5
100	12.0	25.0	6.5	15.0	12.0	25.0	6.5	15.0
150	16.0	35.0	11.5	25.0	16.0	35.0	11.5	25.0

NOTES

- Set pressures are based upon valve discharge into an atmospheric pressure return line. If return line pressure is significantly higher than atmospheric pressure, then consult factory for capacity information.
- For set pressures less than 10 psi (0.69 bar) consult the factory.

CASH VALVE™ FR SERIES BACK PRESSURE VALVES

TYPE FRM-2 WATER CAPACITY (GPM)

Set pressure ⁽¹⁾ , psig	Inlet size ¼ in. (8 mm)				Inlet size ⅜ in. (10 mm)	
	Rubber diaphragm		Metal diaphragm		Rubber diaphragm	
	10% Rise	20% Rise	10% Rise	20% Rise	10% Rise	20% Rise
10 ⁽²⁾	0.5	1.0	0.3	0.7	0.5	1.0
25	0.7	1.7	0.7	1.2	0.7	1.7
50	1.5	3.5	1.0	2.0	1.5	3.5
100	2.7	5.0	2.0	4.0	2.7	5.0
150	3.7	7.5	2.5	5.5	3.7	7.5
200	4.5	8.5	3.0	6.5	4.5	8.5
250	5.5	10.0	4.0	8.0	5.5	10.0

TYPE FRM-2 WATER CAPACITY (GPM) (CONTINUED)

Set pressure ⁽¹⁾ , psig	Inlet size ⅜ in. (10 mm)		Inlet size ½ in. (15 mm)			
	Metal diaphragm		Rubber diaphragm		Metal diaphragm	
	10% Rise	20% Rise	10% Rise	20% Rise	10% Rise	20% Rise
10 ⁽²⁾	0.3	0.7	0.5	1.0	0.3	0.7
25	0.7	1.2	0.7	1.7	0.7	1.2
50	1.0	2.0	1.5	3.5	1.0	2.0
100	2.0	4.0	2.7	5.0	2.0	4.0
150	2.5	5.5	3.7	7.5	2.5	5.5
200	3.0	6.5	4.5	8.5	3.0	6.5
250	4.0	8.0	5.5	10.0	4.0	8.0

TYPE FRM-2 AIR CAPACITY (SCFM)

Set pressure ⁽¹⁾ , psig	Inlet size ¼ in. (8 mm)				Inlet size ⅜ in. (10 mm)	
	Rubber diaphragm		Metal diaphragm		Rubber diaphragm	
	10% Rise	20% Rise	10% Rise	20% Rise	10% Rise	20% Rise
10 ⁽²⁾	5.0	11.0	3.0	8.0	5.0	11.0
25	9.0	14.0	5.0	11.0	9.0	14.0
50	12.0	22.0	7.0	17.0	12.0	22.0
100	16.0	33.0	11.0	25.0	16.0	33.0
150	20.0	42.0	14.0	31.0	20.0	42.0
200	24.0	52.0	17.0	38.0	24.0	52.0
250	26.0	60.0	20.0	43.0	26.0	60.0

TYPE FRM-2 AIR CAPACITY (SCFM) (CONTINUED)

Set pressure ⁽¹⁾ , psig	Inlet size ⅜ in. (10 mm)		Inlet size ½ in. (15 mm)			
	Metal diaphragm		Rubber diaphragm		Metal diaphragm	
	10% Rise	20% Rise	10% Rise	20% Rise	10% Rise	20% Rise
10 ⁽²⁾	3.0	8.0	5.0	11.0	3.0	8.0
25	5.0	11.0	9.0	14.0	5.0	11.0
50	7.0	17.0	12.0	22.0	7.0	17.0
100	11.0	25.0	16.0	33.0	11.0	25.0
150	14.0	31.0	20.0	42.0	14.0	31.0
200	17.0	38.0	24.0	52.0	17.0	38.0
250	20.0	43.0	26.0	60.0	20.0	43.0

NOTES

- Set pressures are based upon valve discharge into an atmospheric pressure return line. If return line pressure is significantly higher than atmospheric pressure, then consult factory for capacity information.
- For set pressures less than 10 psi (0.69 bar) consult the factory.

CASH VALVE™ FR SERIES BACK PRESSURE VALVES

STANDARD SPRING RANGES, psig (bar)

Type	Spring material	Size, in. (mm)	1	2	3	4	5	6	7
FR	Steel	½ (15)	0 to 25 (0 to 1.7)	25 to 45 (1.7 to 3.1)	5 to 50 (0.3 to 3.4)	30 to 100 (2.1 to 6.9)	75 to 175 (5.2 to 12.1)	150 to 400 (10.3 to 27.6)	----
		¾ (20)	0 to 10 (0 to 0.69)	5 to 20 (0.34 to 1.4)	10 to 50 (0.69 to 3.4)	20 to 110 (1.4 to 7.6)	30 to 200 (2.1 to 13.8)	100 to 250 (6.9 to 17.2)	150 to 400 (10.3 to 27.6)
		1 (25)	0 to 20 (0 to 1.4)	10 to 35 (0.69 to 2.4)	20 to 90 (1.4 to 6.2)	40 to 125 (2.8 to 8.6)	50 to 230 (3.4 to 15.9)	175 to 380 (12.5 to 26.2)	300 to 400 (20.7 to 27.6)
		1¼ (32)	0 to 15 (0 to 1.0)	10 to 30 (0.69 to 2.1)	20 to 85 (1.4 to 5.9)	50 to 230 (3.4 to 15.9)	175 to 380 (12.5 to 26.2)	300 to 400 (20.7 to 27.6)	----
		1½, 2 (40, 50)	0 to 10 (0 to 0.69)	5 to 20 (0.34 to 1.4)	10 to 55 (0.69 to 3.8)	30 to 100 (2.1 to 6.9)	40 to 200 (2.8 to 13.8)	125 to 300 (8.6 to 20.7)	200 to 400 (13.8 to 27.6)
	SST	½ (15)	0 to 20 (0 to 1.4)	10 to 50 (0.69 to 3.4)	40 to 90 (2.8 to 6.2)	75 to 200 (5.2 to 13.8)	100 to 300 (6.9 to 20.7)	100 to 400 (6.9 to 27.6)	----
		¾ (20)	0 to 10 (0 to 0.69)	0 to 15 (0 to 1.0)	10 to 70 (0.69 to 4.8)	50 to 175 (3.4 to 12.1)	100 to 265 (6.9 to 18.3)	----	----
		1 (25)	0 to 15 (0 to 1.0)	10 to 35 (0.69 to 2.4)	20 to 75 (1.4 to 5.2)	40 to 200 (2.8 to 13.8)	50 to 250 (3.4 to 17.2)	----	----
		1¼ (32)	0 to 15 (0 to 1.0)	10 to 30 (0.69 to 2.1)	20 to 85 (1.4 to 5.9)	40 to 125 (2.8 to 8.6)	50 to 250 (3.4 to 17.2)	----	----
		1½, 2 (40, 50)	0 to 15 (0 to 1.0)	5 to 20 (0.34 to 1.4)	10 to 55 (0.69 to 3.8)	30 to 100 (2.1 to 6.9)	40 to 160 (2.8 to 11.0)	100 to 250 (6.9 to 17.2)	----

STANDARD SPRING RANGES, psig (bar)

Type	Spring material	Size, in. (mm)	1
FR-6	Steel	All sizes	200 to 600 (13.8 to 41.4)
	SST	½ (15)	200 to 600 (13.8 to 41.4)
		¾, 1, 1¼, 1½, 2 (20, 25, 32, 40, 50)	200 to 400 (13.8 to 27.6)

STANDARD SPRING RANGES, psig (bar)

Type	Spring material	Size, in. (mm)	1	2	3	4	5
FR-10	Steel	½ (15)	0 to 25 (0 to 1.7)	5 to 50 (0.34 to 3.4)	30 to 100 (2.1 to 6.9)	75 to 175 (5.2 to 12.1)	100 to 250 (6.9 to 17.2)
		¾ (20)	0 to 10 (0 to 0.69)	10 to 50 (0.69 to 3.4)	20 to 110 (1.4 to 7.6)	30 to 200 (2.1 to 13.8)	100 to 250 (6.9 to 17.2)
		1, 1¼ (25, 32)	0 to 20 (0 to 1.4)	20 to 90 (1.4 to 6.1)	40 to 125 (2.8 to 8.6)	50 to 250 (3.4 to 17.2)	----
		1½, 2 (40, 50)	0 to 10 (0 to 0.69)	10 to 55 (0.69 to 3.8)	30 to 100 (2.1 to 6.9)	40 to 200 (2.8 to 13.8)	125 to 250 (8.6 to 17.2)
	SST	½ (15)	0 to 20 (0 to 1.4)	10 to 50 (0.69 to 3.4)	40 to 90 (2.8 to 6.2)	75 to 200 (5.2 to 13.8)	100 to 250 (6.9 to 17.2)
		¾ (20)	0 to 10 (0 to 0.69)	10 to 70 (0.69 to 4.8)	50 to 175 (3.4 to 12.1)	100 to 250 (6.9 to 17.2)	----
		1, 1¼ (25, 32)	0 to 15 (0 to 1.0)	10 to 75 (0.69 to 5.2)	40 to 200 (2.8 to 13.8)	50 to 250 (3.4 to 17.2)	----
		1½, 2 (40, 50)	0 to 15 (0 to 1.0)	10 to 55 (0.69 to 3.8)	30 to 100 (2.1 to 6.9)	40 to 160 (2.8 to 11.0)	100 to 250 (6.9 to 17.2)

STANDARD SPRING RANGES, psig (bar)

Type	Spring material	1	2	3	4	5	6	7	8	9
FRM	Steel	1 to 2 (0.07 to 0.14)	2 to 15 (0.14 to 1.0)	2 to 30 (0.14 to 2.1)	10 to 50 (0.69 to 3.4)	40 to 90 (2.8 to 6.2)	40 to 125 (2.8 to 8.6)	75 to 175 (5.2 to 12.1)	----	----
FRM	SST	2 to 25 (0.14 to 1.7)	15 to 65 (1.0 to 4.5)	40 to 100 (2.8 to 6.9)	50 to 150 (3.4 to 10.3)	75 to 175 (5.2 to 12.1)	100 to 250 (6.9 to 17.2)	200 to 400 (13.8 to 27.6)	200 to 600 (13.8 to 41.4)	300 to 600 (20.7 to 41.4)
FRM2		0 to 30 (0 to 2.1)	20 to 50 (1.4 to 3.5)	40 to 80 (2.8 to 5.5)	75 to 150 (5.2 to 10.3)	100 to 275 (6.9 to 19.0)	200 to 400 (13.8 to 27.6)	300 to 600 (20.7 to 41.4)	----	----

CASH VALVE™ FR SERIES BACK PRESSURE VALVES

SELECTION GUIDE

Example:	FR-	Z	A	W	T	C	Z	Z	B	S	01	-	D	1
Model														
FR6	Type FR-6													
FR1	Type FR-10													
FR-	Type FR													
Material of construction														
Z	Bronze (Types FR, FR-6)	G	316 SST (Types FR, FR-6)											
F	Iron (Types FR, FR-10)													
Valve size														
C	½ in. (15 mm)	F	1 ¼ in. (32 mm)											
D	¾ in. (20 mm)	G	1 ½ in. (40 mm)											
E	1 in. (25 mm)	H	2 in. (50 mm)											
Service														
W	Water/air service													
Body/connection style														
S	2 side inlets/bottom outlet - w/NPT connections (Standard)													
B	2 side inlets/bottom outlet - w/BSPT connections (Special)													
E	1 side inlet/bottom outlet - w/NPT connections (standard body with one side plugged)													
Spring chamber style														
S	Standard													
C	W/pressure screw cap													
D	W/pressure screw cap and differential connection													
V	Vented													
Spring chamber material														
Z	Bronze	G	316 Stainless steel											
F	Iron													
Diaphragm material														
B	NBR	M	Monel®											
Z	Bronze (Types FR and FR-6 only)	V	FKM (Type FR10 only)											
G	316 SST (Types FR and FR-6 only)	L	NBR w/ PTFE diaphragm liner											
Body seat material														
E	303 Stainless steel	Z	Brass											
G	316 Stainless steel													
Pressure screw style														
S	Standard	T	T-handle											
Variation														
01	Standard (303 Stainless steel trim) (elastomer diaphragms only)													
02	303 Stainless steel trim w/NBR O-ring and Aramid fiber diaphragm gasket (metal diaphragms only)													
03	303 Stainless steel trim w/PTFE O-ring and Aramid fiber diaphragm gasket (metal diaphragms only)													
04	303 Stainless steel trim w/PTFE O-ring and PTFE diaphragm gasket (metal diaphragms only) (Type FR-10 has PTFE diaphragm liner in place of gasket)													
05	303 Stainless Steel Trim w/ FKM O-Ring & Aramid fiber diaphragm gasket (metal diaphragms only)													
11	316 Stainless steel trim (elastomer diaphragms only)													
12	316 Stainless steel trim w/NBR O-ring and Aramid fiber diaphragm gasket (metal diaphragms only)													
13	316 Stainless steel trim w/PTFE O-ring and Aramid fiber diaphragm gasket (metal diaphragms only)													
14	316 Stainless steel trim w/PTFE O-ring and PTFE diaphragm gasket (metal diaphragms only) (Type FR-10 has PTFE diaphragm liner in place of gasket)													
15	316 Stainless Steel Trim w/FKM O-ring & Aramid fiber diaphragm gasket (metal diaphragms only)													
31	Nitralloy trim (elastomer diaphragms only)													
32	Nitralloy trim w/NBR O-ring and Aramid fiber diaphragm gasket (metal diaphragms only)													
Design revision														
(-)	Indicates original design													
Spring material														
D	Carbon steel (water/air)	E	Stainless steel (optional)											
Spring range														
	Refer to tables on page 13													

Monel® is a mark owned by Special Metals Corporation.

CASH VALVE™ FR SERIES BACK PRESSURE VALVES

SELECTION GUIDE

Example:	FRM-	A	W	Z	S	Z	S	B	F	02	-	D	1
Model													
FRM-	FRM												
FRM2	FRM-2												
Size													
A	¼ in. (8 mm)												
B	⅜ in. (10 mm)												
C	½ in. (15 mm) (Type FRM-2 only)												
Service													
W	Water/air/oil/gas												
Material of construction													
Z	Brass	G	316 SST										
Body/connection style													
S	Side inlet/side outlet NPT												
R	2 side inlets/bottom outlet NPT												
E	Side inlet/bottom outlet NPT												
Spring chamber material													
A	Aluminum spring chamber (Type FRM only)												
Z	Brass spring chamber												
C	Chrome-plated brass												
Spring chamber style													
S	Standard	C	Cap (Type FRM-2 only)	W	Without vent hole								
Diaphragm material													
B	NBR	N	Neoprene	V	FKM								
G	316 Stainless steel	Z	Bronze										
Pressure screw style													
F	Fillister (FRM only)	H	Hex	Q	Square head (Steel for Water/Air service only)								
Variation													
01	Standard (303 Stainless steel trim) (elastomer diaphragms only)												
02	303 Stainless steel trim w/Aramid fiber diaphragm gasket (metal diaphragms only)												
03	303 Stainless steel trim w/PTFE diaphragm gasket (metal diaphragms only)												
05	303 Stainless steel trim w/Nylon inserted locknut												
11	316 Stainless steel trim (elastomer diaphragms only)												
12	316 Stainless steel trim w/Aramid fiber diaphragm gasket (metal diaphragms only)												
13	316 Stainless steel trim w/PTFE diaphragm gasket (metal diaphragms only)												
21	Monel® trim (elastomer diaphragms only)												
22	Monel® trim w/Aramid fiber diaphragm gasket (metal diaphragms only)												
23	Monel® trim w/PTFE diaphragm gasket (metal diaphragms only)												
31	Brass body w/SST body seat												
32	Remote sensing												
UL	UL approved												
Design revision													
(-)	Original design												
Spring material													
D	Carbon steel (industrial or final line gas service only)												
E	Stainless steel (Type FRM-2 only)												
Spring range													
	Refer to table on page 13												

VCTDS-00516-EN © 2016, 2025 Emerson Electric Co. All rights reserved 09/25. Cash Valve is a mark owned by a subsidiary of Emerson Electric Co. The Emerson logo is a trademark and service mark of Emerson Electric Co. All other marks are property of their respective owners.

Neither Emerson nor any of its affiliated entities assume responsibility for the selection, use or maintenance of any product. Responsibility for proper selection, use, and maintenance of any product remains solely with the purchaser and end user.

The contents of this publication are presented for informational purposes only, and while every effort has been made to ensure their accuracy, they are not to be construed as warranties or guarantees, express or implied, regarding the products or services described herein or their use or applicability. All sales are governed by our terms and conditions, which are available upon request. We reserve the right to modify or improve the designs or specifications of such products at any time without notice.

Emerson.com