



## CASH VALVE™ LS SERIES PRESSURE REDUCING AND REGULATING VALVES

High pressure single-seated, spring loaded, direct acting diaphragm type regulators for inlet pressures to 2400 psig (165.5 barg)



### FEATURES

- Automatically reduce high inlet pressures to lower outlet pressures within close limits regardless of fluctuations.
- Designed for use on air, water, oil, oxygen, carbon dioxide and other gases and fluids.
- Designed and built to meet the rugged requirements of high pressure regulation and reduction.
- Exceptional flow characteristics.
- Stainless steel piston/piston assemblies, cylinders, seat ring and strainer screens as standard.
- Nitrile (NBR), fluorocarbon (FKM) and bronze diaphragm and NBR, FKM and polytetrafluoroethylene (PTFE) O-rings.
- Self-renewable seat ring is simply flipped over and re-installed rather than replaced.
- NPTF 'Dryseal' threaded ends as standard.
- Closing cap or T-handle adjusting screw options available.

### GENERAL APPLICATION

The LS Series Pressure Reducing and Regulating Valves are recommended for use on high pressure test rigs and pressure vessel or casting test equipment, hydraulic cylinders and air tanks.

### TECHNICAL DATA<sup>(1)</sup>

Materials:	Bronze
Sizes:	½ and ¾ in. (15 and 20 mm)
Connections:	NPTF
Maximum inlet pressure:	2400 psig (165.5 barg)
Reduced pressure range:	40 to 750 psig (2.8 to 51.7 barg)
Temperature range:	-40 to 180°F (-40 to 82°C)

1. Refer to General Specifications Table in page 2 for more information.

# CASH VALVE™ LS SERIES PRESSURE REDUCING AND REGULATING VALVES

## MODELS OVERVIEW

All LS Series valves are designed and built to meet the rugged requirements of a high pressure regulating and reducing valve with a bronze body, spring chamber and bottom plug. Four versions are available:

**Type LS1** has a metal seat piston and cylinder particularly designed for high or low temperature and high pressure drop applications.

**Type LS2** has an NBR seat and balanced piston design for applications requiring higher capacities and/or tight shut-off. The balanced design assures close control regardless of inlet pressure fluctuations.

**Type LS3** is furnished with a modified cylinder and no strainer screen for applications involving heavy or high viscosity fluids.

**Special note:** Although the metal to metal seat in the Types LS1 and LS3 is stainless steel, which assures maximum seat life and good closure, it will not shut-off drip tight. For installations requiring a definite pressure maximum on the downstream side, it is recommended that a Cash Valve Type FR back pressure valve is installed close to the outlet of the Types LS1 or LS3 regulators. For full information on the Type FR, see datasheet VCTDS-00516.

## OPTIONS

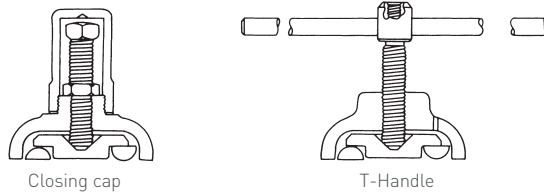

## LS SERIES INTERIOR DETAILS

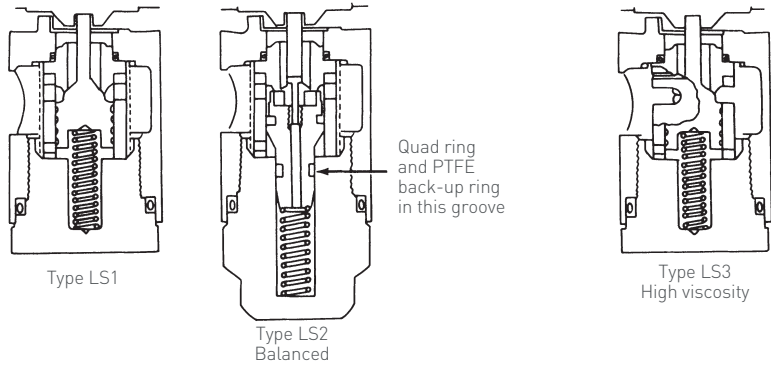

## GENERAL SPECIFICATIONS

Type	Body Material	Spring Chamber Material	Body Size, in. (mm)	Materials			Maximum Inlet Pressure, psig (barg)	Maximum Outlet Pressure, psig (barg)	Temperature, °F [°C]
				Trim	Diaphragm	O-ring			
LS1	Bronze	Bronze	1/2, 3/4 (15, 20)	Standard	NBR, FKM or Bronze	NBR, FKM or PTFE	2400 (165.5)	750 (51.7)	-40 to 180 (-40 to 82)
LS2	Bronze	Bronze	1/2, 3/4 (15, 20)	Balanced	NBR, FKM or Bronze	NBR	2400 (165.5)	750 (51.7)	-40 to 180 (-40 to 82)
	Bronze	Bronze	1/2, 3/4 (15, 20)	Non-balanced	NBR, FKM or Bronze	NBR, FKM or PTFE	2400 (165.5)	750 (51.7)	-40 to 180 (-40 to 82)
LS3	Bronze	Bronze	1/2, 3/4 (15, 20)	Standard	NBR, FKM or Bronze	NBR, FKM or PTFE	2400 (165.5)	750 (51.7)	-40 to 180 (-40 to 82)

## STANDARD SPRING RANGES, psig (barg)

Type	Size, in. (mm)	Spring Material	Spring ranges
LS1, LS2 and LS3	1/2 and 3/4 (15 and 20)	Steel	40 to 200 (2.8 to 13.8)
			40 to 350 (2.8 to 24.1)
			40 to 500 (2.8 to 34.5)
			400 to 750 (6.9 to 51.7)

# CASH VALVE™ LS SERIES PRESSURE REDUCING AND REGULATING VALVES

LS SERIES PARTS

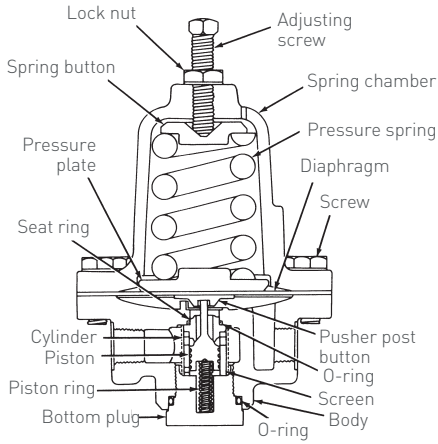

LS SERIES DIMENSIONS

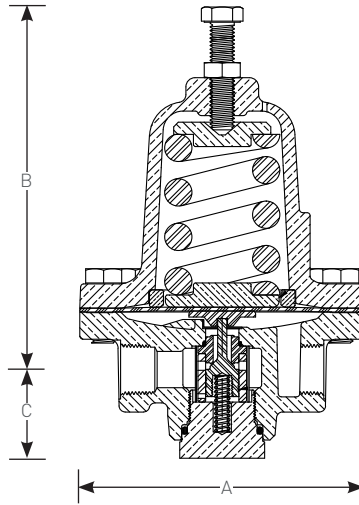

LS SERIES

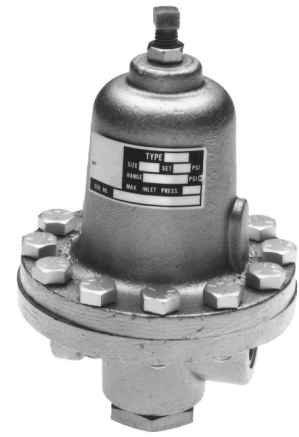

## DIMENSIONS

Type	Size, in. (mm)	Dimensions, in. (mm)			Shipping weight, lbs (kg)
		A	B	C	
LS1, LS2 and LS3	½ and ¾ (15 and 20)	5.88 (149.2)	7.63 (193.1)	2.00 (50.8)	20 (9.1)

## CAPACITIES (ALL SIZES<sup>(1)</sup>)

Inlet pressure, psig	Outlet pressure, psig	Water capacity GPM			Air capacity SCFM		
		5% Fall-off	10% Fall-off	15% Fall-off	5% Fall-off	10% Fall-off	15% Fall-off
500	400	5	10	15	63	126	189
	250	6	12	18	74	148	222
	150	6	12	18	74	148	222
	100	6	12	18	74	148	222
750	500	7	14	21	105	210	325
	300	8	16	24	109	218	227
	150	9	18	27	109	218	227
	100	9	18	27	109	218	227
1000	750	7	14	21	135	270	405
	500	9	18	27	138	276	414
	300	10	20	30	138	276	414
	100	10	20	30	138	276	414
1500	750	11	22	33	220	440	660
	500	12	24	36	220	440	660
	300	13	26	39	220	440	660
	150	14	28	42	220	440	660
2000	750	14	28	42	293	586	879
	500	15	30	45	293	586	879
	300	16	32	48	293	586	879
	200	17	34	51	293	586	879
2400	750	17	33	50	351	703	1054
	500	18	35	53	351	703	1054
	300	19	37	56	351	703	1054
	200	20	39	59	351	703	1054

1. The above data reflects regulator flow capacities, in some cases this capacity may represent flow velocities which exceed recommended piping practices.

2. To obtain capacities for regulators using metal diaphragms, multiply the table values by 0.7

# CASH VALVE™ LS SERIES PRESSURE REDUCING AND REGULATING VALVES

## SELECTION GUIDE

Example:	LS1	B	S	B	S	01	-	D	1
<b>Model</b>									
<b>LS1</b> Type LS1 (metal to metal seat)									
<b>LS2</b> Type LS2 (PTFE soft seat)									
<b>LS3</b> Type LS3 (metal to metal for heavy fluids)									
<b>Valve size</b>									
<b>C</b> ½ in. (15 mm)									
<b>D</b> ¾ in. (20 mm)									
<b>Spring chamber style</b>									
<b>S</b> Standard									
<b>C</b> With adjusting screw cap									
<b>Diaphragm material</b>									
<b>B</b> NBR									
<b>Z</b> Bronze									
<b>V</b> FKM									
<b>Adjusting screw style</b>									
<b>S</b> Standard									
<b>T</b> T-handle									
<b>Variation</b>									
<b>01</b> Standard (NBR O-rings)									
<b>02</b> FKM O-rings (Types LS1 and LS3 only)									
<b>03</b> PTFE O-rings (Types LS1 and LS3 only)									
<b>11</b> Type LS2 with non-balanced piston and NBR O-rings									
<b>12</b> Type LS2 with non-balanced piston and FKM O-rings									
<b>13</b> Type LS2 with non-balanced piston and PTFE O-rings									
<b>Design revision</b>									
<b>(-)</b> Indicates original design									
<b>Spring material</b>									
<b>D</b> Carbon steel									
<b>Spring range</b>									
Refer to table in page 2									

VCTDS-00513 © 2016, 2025 Emerson Electric Co. All rights reserved 09/25. Cash Valve is a mark owned by a subsidiary of Emerson Electric Co. The Emerson logo is a trademark and service mark of Emerson Electric Co. All other marks are property of their respective owners.

Neither Emerson nor any of its affiliated entities assume responsibility for the selection, use or maintenance of any product. Responsibility for proper selection, use, and maintenance of any product remains solely with the purchaser and end user.

The contents of this publication are presented for informational purposes only, and while every effort has been made to ensure their accuracy, they are not to be construed as warranties or guarantees, express or implied, regarding the products or services described herein or their use or applicability. All sales are governed by our terms and conditions, which are available upon request. We reserve the right to modify or improve the designs or specifications of such products at any time without notice.

Emerson.com