



CASH VALVE TYPE FRM CRYOGENIC BACK PRESSURE OR ECONOMIZER VALVE INSTALLATION, MAINTENANCE AND REPAIR PARTS INFORMATION

Before installation, these instructions must be read carefully and understood.



GENERAL INSTALLATION INSTRUCTIONS

Type FRM valves are available with three different body styles for pipe connections to enable it to be adapted to most any system: side inlet-side outlet, side inlet-bottom outlet, 2 opposite side inlets-bottom outlet.

When installing the valve, connect the supply line to the inlet connection. The outlet connection should be connected to the bypass or final vaporizer line. Valves with 2 opposite side inlets and a bottom outlet may be installed as an angle valve with one inlet plugged, or alternitavely used as an in-line valve with regulated pressure on both the inlet and process sides of the valve.

It is recommended that Type FRM valves be installed in the horizontal position with the spring chamber upright. For ease of operation and maintenance, it is suggested that manual shut-off valves be installed upstream and downstream from the valve. Use a compatible sealant on the male pipe threads and do not overtighten the valve connections.

Other considerations in making a good installation are:

1. The valve should be sized properly for the service conditions.
2. Type FRM valves are diaphragm operated valves designed for the continuous operating pressure control of a system. All Type FRM valves are fitted with a diaphragm travel stop to prevent the diaphragms from extending beyond their limit; however, should a diaphragm fail, the valve will fail in the closed position. As a safeguard, it may be desirable to protect the system against damaging high pressures by a safety relief valve or some other type of safety device.

DESCRIPTION

The Type FRM is designed to function as a Back Pressure or Economizer valve in Cryogenic Circuits. The Back Pressure Function is to open at a preset pressure and relieve inlet pressure to the discharge side into a lower pressure. The Economizer function is to open at a preset pressure, above the Pressure Build set pressure, and continue to open as gas head pressure from heat leak builds during non-use periods of the system. The Economizer by-passes gas head pressure directly to the Final Line circuit, when system draw resumes, to draw down the excess pressure rapidly and recloses before the Pressure Build regulator opens. The Type FRM valve is small and compact, yet is highly efficient making it suitable for numerous applications that call for a small, accurate back pressure regulator. The Type FRM incorporates a "floating ring" design that provides for smooth even pressure control.

SPECIFICATION DATA

Service: Cryogenic liquids and gases. Well suited for use in the Economizer circuit as a heat leak economizer valve in systems having relatively low flows.
Sizes: 1/4" or 3/8"
Connections: Threaded female inlet and outlet connections
Body: Bronze
Maximum Temperature: +150°F (66°C) to -320°F (-196°C)
Maximum Set Pressure: 600 psi (41 bar)
Shipping Weight: 1 1/8 lbs.
Capacity: For specific capacity information, consult the factory.

CONSTRUCTION

Forged Bronze body; Stainless Steel seat disc, seat ring and pressure spring; Phosphor Bronze diaphragms with Teflon diaphragm gaskets.

All parts commercially cleaned for cryogenic service.

CASH VALVE TYPE FRM CRYOGENIC BACK PRESSURE OR ECONOMIZER VALVE

INSTALLATION, MAINTENANCE AND REPAIR PARTS INFORMATION

OPERATING INSTRUCTIONS

Adjusting the Back Pressure

The regulator's back pressure setting is adjusted by turning the adjusting screw (1) at the top of the spring chamber after loosening the adjusting screw lock nut (2). To obtain a higher pressure setting, turn the adjusting screw clockwise (into the spring chamber). To lower the pressure setting, turn the adjusting screw counter-clockwise (out of the spring chamber). Tighten the adjusting screw lock nut after the adjustment has been made and install the closing cap.

MAINTENANCE INSTRUCTIONS

The following procedures are provided for servicing the Type FRM back pressure relief valve. Repair parts can easily be installed without removing the valve from the line.

CAUTION

Before attempting to replace any spare parts, be sure to shut off all pressure connections to the valve. With the valve closed, however, system pressure could still be locked between the shut off valve and the inlet and/or outlet sides of the relief valve. Before proceeding with any valve service, be certain to relieve the pressure from BOTH sides of the valve.

Refer to the Type FRM exploded view for parts identification.

Servicing the Pressure Spring (5), Diaphragms (11), Seat Disc Gasket (13), Seat Disc (14) and Seat Ring (15)

- Loosen the lock nut (2) 1/4 turn and turn the adjusting screw (1) counter-clockwise until the pressure spring (5) is no longer under tension.

NOTE

When installing the adjusting screw during reassembly, turn the screw clockwise until the lock nut just touches the spring chamber. When the valve is placed in service, the pressure setting should be very close to the original setting.

- Unscrew the spring chamber (3) from the valve body (16). During reassembly, tighten the spring chamber securely.
- Remove the spring seat (4), pressure spring (5), diaphragm stop (6), and the upper diaphragm gasket (7) from the valve body.

- The Diaphragm assembly, consisting of the pressure plate nut (8), lock washer (9), diaphragm pressure plate (10), diaphragms (11), seat disc gasket (13) and seat disc (14), can now be lifted off the body (16). Disassemble the parts by unscrewing the pressure plate nut (8) from the seat disc (14). Inspect all parts and replace if necessary. The diaphragm gasket (12) below the diaphragm should be replaced when new diaphragms (11) are installed.

IMPORTANT

Exercise care to ensure that the surface of the seat disc (14) is not scratched, marred or damaged during disassembly and reassembly.

- Once the diaphragm assembly has been removed, the seat ring (15), which is sitting loosely in a recess of the valve body, can be removed.

IMPORTANT

Handle the seat ring carefully to avoid damage to the seat ring surface which contacts the seat disc (14).

NOTE

Be sure to install the seat disc, with the machined groove around the outer edge of the flat face, so that this face is up (away from the body).

- Inspect all parts and replace if necessary. Reassemble in reverse order. After placing the valve back in service, adjust the delivery pressure setting as detailed under Operating Instructions.

REPAIR PARTS INFORMATION

Refer to the Type FRM exploded view for parts identification.

SPECIFICATIONS

Each Type FRM back pressure valve is supplied with a pressure spring selected to provide the desired pressure setting. The range of adjustment or satisfactory "working range" of individual springs is shown in the table below for each valve. Each valve has the "set" pressure and range or adjustment stamped on a tag fastened to the valve.

SPRING RANGES

SPRING RANGE (psi)							
2-25	15-65	40-100	50-100	75-175	100-250	200-400	200-600 300-600

CASH VALVE TYPE FRM CRYOGENIC BACK PRESSURE OR ECONOMIZER VALVE

INSTALLATION, MAINTENANCE AND REPAIR PARTS INFORMATION

LIST OF MATERIALS

Item No.	Description
1	Adjusting Screw
2	Lock Nut
3	Spring Chamber
4	Spring Seat
5	Pressure Spring
6	Diaphragm Travel Stop
7	Diaphragm Gasket
8	Pressure Plate Nut
9	Lock Washer
10	Pressure Plate
11	Diaphragm
12	Diaphragm Gasket
13	Seat Disc Gasket
14	Seat Disc
15	Seat Ring
16	Body

FIGURE 1

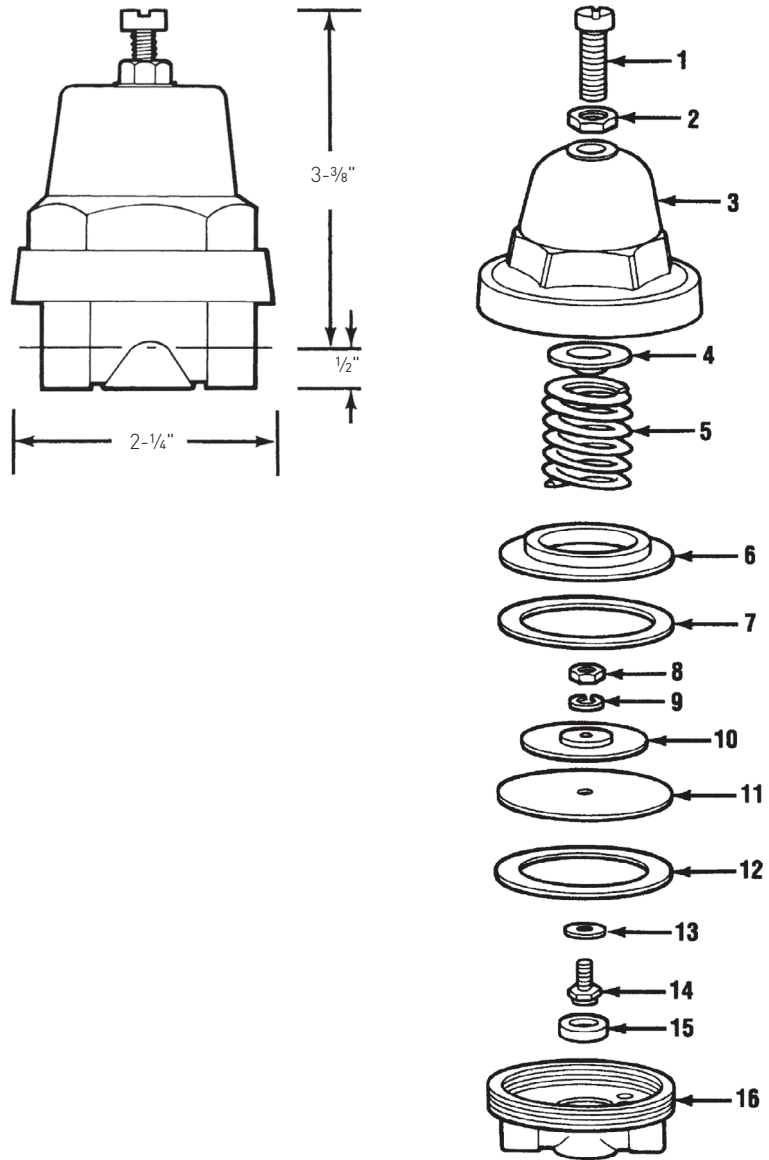

Neither Emerson, Emerson Automation Solutions, nor any of their affiliated entities assumes responsibility for the selection, use or maintenance of any product. Responsibility for proper selection, use, and maintenance of any product remains solely with the purchaser and end user.

Cash Valve is a mark owned by one of the companies in the Emerson Automation Solutions business unit of Emerson Electric Co. Emerson Automation Solutions, Emerson and the Emerson logo are trademarks and service marks of Emerson Electric Co. All other marks are the property of their respective owners.

The contents of this publication are presented for informational purposes only, and while every effort has been made to ensure their accuracy, they are not to be construed as warranties or guarantees, express or implied, regarding the products or services described herein or their use or applicability. All sales are governed by our terms and conditions, which are available upon request. We reserve the right to modify or improve the designs or specifications of such products at any time without notice.