



CASH VALVES TYPE G-4 PRESSURE REGULATORS

A self-actuating pilot operated pressure reducing valve handling air, gas and steam and accurate to within 1/2% up to 3" and 1% for sizes to 6"



FEATURES

- Extremely compact design enables use of a smaller regulator.
- Constant outlet pressure up to the valve's maximum rated capacity regardless of changes in flow rate or inlet pressure.
- Very high flow rates due to the main valve assembly's full lift capability valve body design.
- Positive shut-off ensured by accurate guiding of the pilot and main valve assemblies. Non-metallic trims available for dead tight shut-off on air and gas applications.
- Pilot valve component parts interchangeability simplifies maintenance and allows greater spare parts flexibility.
- Available in bronze, cast iron and steel construction to allow for pressures up to 600 psi and temperatures up to 800°F.
- Specially prepared parts kits enable simple routine servicing or complete overhauls.

GENERAL APPLICATION

Suitable for use on steam heating lines, dryers, ovens, oil heaters, molding machines, steam jacketed equipment, sterilizers, large capacity kilns, retorts, heat exchangers, paper and board machines, cookers and any other steam, air and gaseous application.

TECHNICAL DATA

Materials: Iron, bronze, cast and stainless steels
Sizes: 1/2" to 2" threaded
1/2" to 6" flanged
Maximum inlet pressure: 600 psig (41.3 barg)
Reduced pressure range: 1 to 300 psig (.07 to 20.7 barg)
Max. temperature: 800°F (427°C)

CASH VALVES TYPE G-4 PRESSURE REGULATORS

Description

Fig. 2042 - Bronze



Fig. 2043 - Bronze



Fig. 2044 - Cast iron



Fig. 2046 - Cast steel



Size range ins	1/2	3/4	1	1 1/4	1 1/2	2	2 1/2	3	4	5	6	1/2	3/4	1	1 1/4	1 1/2	2	2 1/2	3	4	5	6		
Maximum inlet press/temp ratings	Pressure/temperature ratings are strictly in accordance with the table below																							
Reduced pressure range psig	5*-300					5*-300					5*-235 air and gases 5*-175 steam		5-175		5-300						5-175			
Flanges ANSI	NPTF					CL150 and CL300 per ANSI B16.24					CL125 per ANSI B16.1		CL150 and CL300 per ANSI B16.5											

***Note:** 1 to 5 psig reduced pressure available with low pressure top maximum inlet pressure 100 psig

- (1/2") and (3/4") sizes restricted internals in 1" body.
- (1 1/4") and (1 1/2") sizes restricted internals in 2" body.

PRESSURE TEMPERATURE RATINGS

Description	Material ASTM spec.	End connection ANSI Class	Pressure (psig)						
			0 to 150F	250F	300F	400F	450F	500F	750F
Cast Iron	A126 Class B	CL125 (iron)	200	175	160	135	125	-	-
Bronze	B62 Alloy 836	CL150 (bronze)	225	195	180	150	-	-	-
		CL300 (bronze)	500	425	390	300	-	-	-
		CL250 (bronze threaded)	400	365	300	250	-	-	-
Carbon steel	A216 GR WCB A351 CF8 (304)	CL150 (steel)	285	245	230	195	185	170	*
		CL300 (steel)	740	660	655	630	615	590	500
		CL250 (steel threaded)	600	530	525	500	490	470	460

* 570°F for 150 psig

MINIMUM PRESSURE DIFFERENTIAL

The pressure differential is the difference between the inlet pressure and outlet (reduced) pressure. The minimum allowable pressure differential varies depending upon both the inlet pressure and the size of the valves.

Valve size	Inlet press. range (psig)	Minimum press. differential (psig)
1/2"-2"	10-50	5
	50-120	10
	120 PLUS	15
2 1/2"-4"	10-50	10
	50 PLUS	15
5"-6"	Refer to sales office	Refer to sales office

CASH VALVES TYPE G-4 PRESSURE REGULATORS

Typical installation

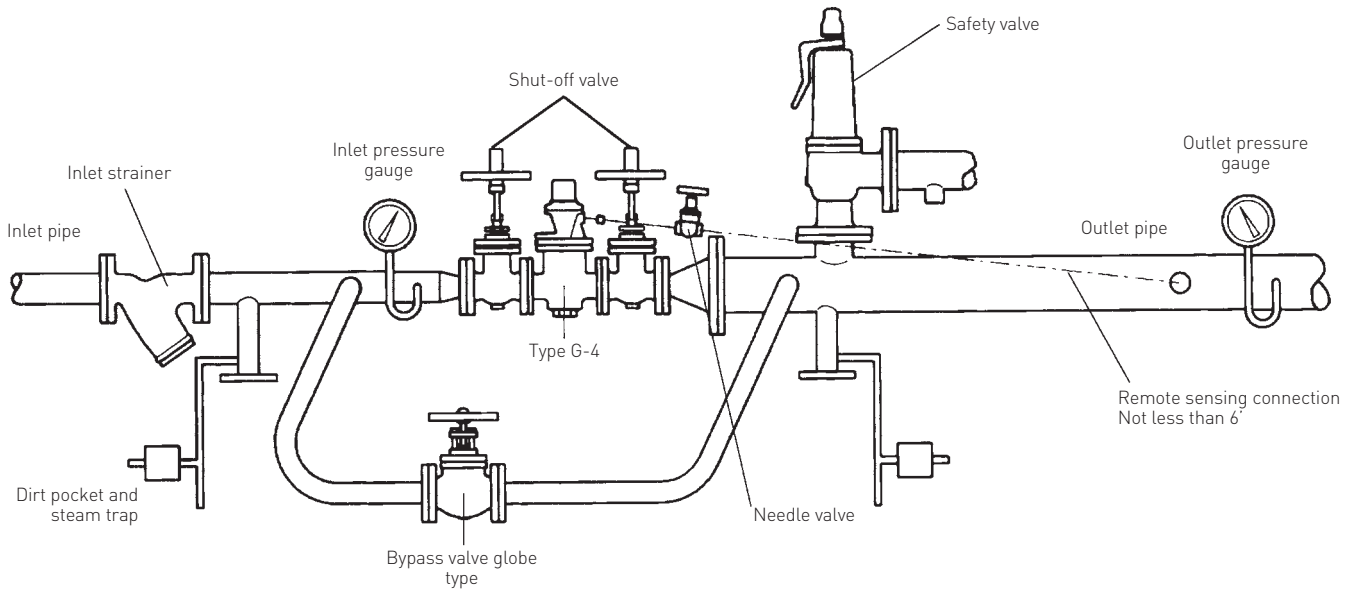

OPERATION

The G-4 regulator is primarily designed for use on steam although it works equally well with air and gases. It will maintain a constant pressure irrespective of variations in inlet pressure or steam demand from the system.

Steam at inlet pressure passes through the inlet relay port (G) to the pilot valve (D). Both pilot and main valves (H) initially are closed by the action of the pilot and main valve springs (E and I).

The pilot valve is opened by clockwise rotation of the adjusting screw (A) which compresses the adjusting spring (B) and applies load to the topside of the diaphragm (C), pushing open the pilot valve. Steam at inlet pressure now passes through the pilot valve and a relay port (K) to the piston (F), which pushes open the main valve.

The inlet steam pressure is reduced as it passes through the open main valve and seat to the valve outlet. At the same time steam at outlet pressure passes up the relay port (L) to the underside of the diaphragm.

The opening of the main valve determines the outlet pressure and this, in turn, is controlled by the pilot valve. The outlet pressure is a result of balancing the action of the adjusting spring on the top of the diaphragm against the reduced pressure acting on the underside, thus controlling the opening of the pilot valve.

The sensitivity of the diaphragm and adjusting spring ensure that any variation in reduced pressure will cause the pilot valve to open or close sufficiently to move the piston and main valve between the fully open and closed positions. In this way, the outlet pressure is maintained accurately under all operating conditions. Outlet pressure is increased by clockwise rotation of the adjusting screw or decreased by counter-clockwise rotation.

SECTION VIEW

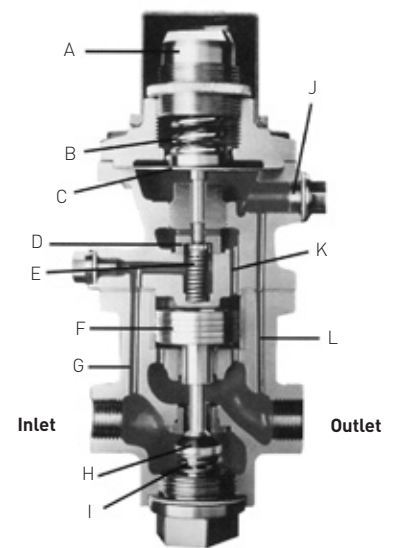

- A. Adjusting screw
- B. Adjusting spring
- C. Diaphragm
- D. Pilot valve
- E. Pilot valve spring
- F. Piston
- G. Inlet relay port
- H. Main valve
- I. Main valve spring
- J. Remote control port
- K. Piston relay port
- L. Reduced pressure relay port

CASH VALVES TYPE G-4 PRESSURE REGULATORS

Specifications

DIMENSIONS

	Fig. 2042						Fig. 2043					
Size	1/2	3/4	1	1 1/4	1 1/2	2	1/2	3/4	1	1 1/4	1 1/2	2
A	4 1/8	4 1/8	4 1/2	4 7/8	5 1/4	6 3/8	5 1/2	5 5/8	6 3/4	7	7 1/2	8 1/2
B	8	8 1/4	8 3/8	9 5/8	9 7/8	10 1/4	8	8 1/4	8 3/8	9 5/8	9 7/8	10 1/4
C	2 3/8	2 1/2	2 5/8	3	3 1/8	3 1/4	2 3/8	2 1/2	2 5/8	3	3 1/8	3 1/4
Wt.lb.	13.2	15.0	15.4	23.8	28.0	33.9	17.6	18.9	19.8	30.0	35.9	45.8

	Fig. 2044						Fig. 2046					
Size	2 1/2	3	4	5	6	1	2	2 1/2	3	4	5	6
A	10	11 1/4	13 1/2	16	16 1/2	6 3/4	9	10	11 1/4	13 1/2	16	16 1/2
B	11 3/4	12	13 3/8	16 3/4	17 5/8	8 3/4	10 1/2	11 1/4	11 1/4	12 3/4	15 3/4	16 1/2
C	5 1/4	5 3/4	6 7/8	9	9 3/4	2 3/4	3 1/2	5 1/8	5 3/4	7	8 5/8	9 3/4
Wt.lb.	77.0	104.0	174.0	247.0	351.0	30.0	58.0	93.0	115.0	192.0	273.0	381.0

STANDARD ASSEMBLY

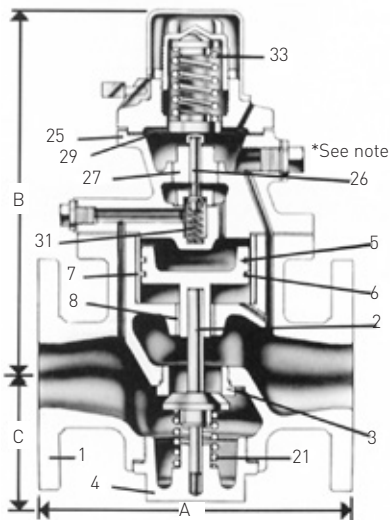

LOW PRESSURE TOP ASSEMBLY

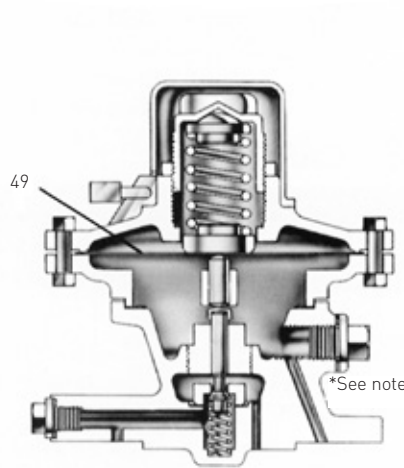

REMOTE CONTROL

*NOTE

We recommend a remote sensing connection be fitted whenever:

1. The outlet pressure is below 55% of the inlet pressure.
 2. A low pressure top assembly is fitted.
 3. Difficult outlet pipework conditions occur.
- Please refer to factory for more details.

A special low pressure top assembly should be fitted for outlet pressures from 1 up to 5 psig (0.07 to 0.3 barg). Low pressure tops are available for valves up to 4" (100 mm) size. Larger valves are not suitable for outlet pressures of less than 5 psig (0.3 barg).

The low pressure top is supplied as a complete conversion unit for fitting to the existing pilot valve assembly. It incorporates a large diaphragm, providing a greater effective area and improved sensitivity to very low outlet pressure conditions.

CASH VALVES TYPE G-4 PRESSURE REGULATORS

Specifications

SPRINGS

VALVE SIZE

1/2" - 4"		5" and 6"*
1 - 5		5 - 20
5 - 50	(Yellow)	10 - 50
10 - 100	(Black)	40 - 100
40 - 150	(White)	50 - 175
50 - 200	(Green)	
100 - 300	(Red)	

NOTE

It is advisable to select a spring which will ensure that there is at least 10% extra adjustment available above the required reduced set pressure. The spring with the lowest pressure range should be used whenever possible.

*Not color coded

MATERIALS OF CONSTRUCTION

Part no.	Part	Figure 2042 and 2043	Figure 2044	Figure 2046
1	Body	Bronze	Cast iron	Cast steel
2	Main valve*	Stainless steel	Stainless steel	Stainless steel
3	Main valve seat	Stainless steel	Stainless steel	Stainless steel
4	Bottom plug cover	Manganese bronze	Cast iron/aluminum bronze	Stainless steel
5	Piston	Brass	Bronze	Steel
6	Piston rings	Phosphor bronze	Phosphor bronze	Chrome iron
7	Liner	Stainless steel	Stainless steel	Stainless steel
8	Piston guide	Stainless steel	Stainless steel	Stainless steel (6" Monel®)
21	Main valve spring	Stainless steel	Stainless steel	Stainless steel
25	Pilot valve top	Bronze	Bronze	Steel
26	Pilot valve*	Stainless steel	Stainless steel	Stainless steel
27	Pilot valve plug	Stainless steel	Stainless steel	Stainless steel
29	Diaphragm	Stainless steel	Stainless steel	Stainless steel
31	Pilot valve spring	Stainless steel	Stainless steel	Stainless steel
33	Adjusting spring	Steel	Steel	Steel
49	Diaphragm for low pressure top	Phosphor bronze	Phosphor bronze	N/A

Gaskets: Steam-non-asbestos material. Air and gases-PTFE (2" and below) rubber bonded cork (2½" and above).

*Main and pilot valves are fitted with elastomeric inserts for use on air and gases when tight shut-off is required.

Note: for full parts list please refer to installation and maintenance instructions available on request.

TRIM SELECTION

	Duty	Trim
Standard valve	Steam	Stainless steel
Standard valve	Compressed air, carbon dioxide, nitrogen, hydrogen, helium	Nitrile
Oxygen Fig. 2043/3 only	Oxygen, methane	FKM

CASH VALVES TYPE G-4 PRESSURE REGULATORS

Specifications - capacities

Inlet pressure	Outlet pressure	Steam - pounds per hour										
		½	¾	1	1¼	1½	2	2½	3	4	5	6
Flow coefficient (C _v)		2.1	4.3	7.1	10.7	15.6	26.8	42.9	53.4	95.6	138.7	197.5
25	20	122	249	410	625	904	1555	-	-	-	-	-
	15	142	290	478	728	1053	1810	2903	3620	6940	9393	13379
	5	151	308	507	773	1118	1921	3082	3843	6889	9971	14202
50	45	160	327	540	823	1189	2044	-	-	-	-	-
	25	254	518	853	1300	1880	3231	5183	6463	11586	16769	23884
	5	254	518	853	1300	1880	3231	5183	6463	11586	16769	23884
75	65	240	490	807	1230	1778	3057	-	-	-	-	-
	60	274	560	923	1407	2034	3496	5401	6735	12073	17474	24887
	40	351	717	1182	1801	2603	4475	7178	8951	16045	23223	33076
	5	351	717	1182	1801	2603	4475	7178	8951	16045	23223	33076
100	90	275	562	926	1411	2039	3505	-	-	-	-	-
	85	318	650	1071	1632	2360	4056	5984	7463	13377	19362	27576
	55	453	924	1522	2319	3352	5762	9241	11524	20657	29899	42583
	5	453	924	1522	2319	3352	5762	9241	11524	20657	29899	42583
125	110	356	728	1199	1827	2641	4540	6486	8088	14499	20985	29888
	65	555	1133	1866	2844	4111	7067	11334	14134	25334	36668	52225
	10	555	1133	1866	2844	4111	7067	11334	14134	25334	36668	52225
	5	555	1133	1866	2844	4111	7067	11334	14134	25334	-	-
150	135	391	798	1315	2004	2897	4980	6850	8543	15313	22164	31568
	80	659	1344	2215	3375	4878	8385	13448	16771	30061	43509	61968
	10	659	1344	2215	3375	4878	8385	13448	16771	30061	43509	61968
	5	659	1344	2215	3375	4878	8385	13448	16771	30061	-	-
200	185	440	898	1479	2254	3258	5600	7096	8850	15863	-	-
	175	550	1122	1848	2816	4071	6998	10044	12525	22451	33150	47200
	110	852	1738	2863	4363	6306	10841	17386	21682	38864	56250	80114
	40	852	1738	2863	4363	6306	10841	17386	21682	38864	56250	80114
250	235	492	1003	1653	2519	3641	6260	7378	9200	16492	-	-
	175	941	1920	3162	4818	6964	11972	19200	23944	42918	62420	88913
	135	1054	2151	3544	5401	7806	13418	21519	26836	48103	69622	99159
	100	1054	2151	3544	5401	7806	13418	21519	26836	48103	69622	99159
	55	1054	2151	3544	5401	7806	13418	21519	26836	48103	69622	99159
300	285	542	1105	1821	2775	4011	6895	7619	9501	17030	-	-
	175	904	2527	4163	6344	9170	15762	25279	31525	56507	81935	116696
	165	1255	2560	4218	6427	9289	15968	25609	31936	57244	82854	118004
	100	1255	2560	4218	6427	9289	15968	25609	31936	57244	82854	118004
	75	1255	2560	4218	6427	9289	15968	25609	31936	57244	82854	118004

These capacities are based on a 3% variance from the regulator's set point.

CASH VALVES TYPE G-4 PRESSURE REGULATORS

Specifications - capacities

		Type G-4 air (SCFM) capacity information										
Inlet pressure	Outlet pressure	½	¾	1	1¼	1½	2	2½	3	4	5	6
Flow coefficient (C _v)		2.1	4.3	7.1	10.7	15.6	26.8	42.9	53.4	95.6	138.7	197.5
25	20	38	79	130	199	288	495	-	-	-	-	-
	15	45	93	153	234	338	582	934	1165	2088	3022	4304
	5	48	99	163	249	360	620	994	1240	2224	3218	4584
50	45	49	100	165	251	363	625	-	-	-	-	-
	25	80	164	271	413	597	1026	1646	2053	3680	5326	7586
	5	80	164	271	413	597	1026	1646	2053	3680	5326	7586
75	65	73	150	247	377	544	936	-	-	-	-	-
	60	85	174	286	436	631	1085	1670	2083	3733	5404	7696
	40	111	227	374	570	823	1416	2271	2832	5077	7349	10466
	5	111	227	374	570	823	1416	2271	2832	5077	7349	10466
100	90	82	168	276	421	609	1047	-	-	-	-	-
	85	96	197	325	496	717	1283	1802	2247	4028	5831	8305
	55	142	289	477	727	1050	1806	2897	3612	6475	9372	13349
	5	142	289	477	727	1050	1806	2897	3612	6475	9372	13349
125	110	108	220	363	553	799	1374	1894	2412	4225	6260	8915
	65	175	357	589	897	1297	2229	3576	4459	7994	11570	16479
	10	175	357	589	897	1297	2229	3576	4459	7994	11570	16479
	5	175	357	589	897	1297	2229	3576	4459	7994	-	-
150	135	116	237	390	595	861	1480	1936	2442	4412	6441	9174
	80	206	421	693	1056	1527	2625	4210	5250	9411	13622	19401
	10	206	421	693	1056	1527	2625	4210	5250	9411	13622	19401
	5	206	421	693	1056	1527	2625	4210	5250	9411	-	-
200	185	128	262	432	659	952	1637	1987	2478	4443	-	-
	175	166	338	557	850	1228	2111	2987	3725	6677	9877	14082
	110	268	547	901	1374	1986	3414	5476	6829	12241	17717	25234
	40	268	547	901	1374	1986	3414	5476	6829	12241	17717	25234
250	235	190	286	472	720	1040	1788	2030	2546	4480	-	-
	175	292	596	928	1496	2163	3718	5963	7437	13330	19390	27620
	135	330	674	1111	1693	2447	4207	6747	8414	15082	21829	31091
	100	330	674	1111	1693	2447	4207	6747	8414	15082	21829	31091
	55	330	674	1111	1693	2447	4207	6747	8414	15082	21829	31091
300	285	152	310	511	757	1126	1901	2075	2600	4502	-	-
	175	387	790	1301	1983	2867	4928	7904	9857	17668	25623	36494
	165	392	801	1320	2011	2907	4998	8015	9996	17917	25993	36935
	100	392	801	1320	2011	2907	4998	8015	9996	17917	25993	36935
	75	392	801	1320	2011	2907	4998	8015	9996	17917	25993	36935

These capacities are based on a 3% variance from the regulator's set point.

Gas	Oxygen	Nitrogen	Hydrogen	Helium	CO ₂	Argon	Methane
Factor	1.05	0.98	0.26	0.37	1.24	1.18	0.74

To find valve capacities for gases at ambient temperatures multiply required flow rate by Approximate factor. Use chart above for valve capacity.

CASH VALVES TYPE G-4 PRESSURE REGULATORS

HOW TO ORDER

Specify Cash Valve type G-4 and state:

1. Pipe size
2. End connections
3. Inlet pressure
4. Outlet pressure range and setting
5. Maximum flow rate desired
6. Service
7. Trim
8. Body material
9. Operating temperature
10. For remote sensing: order remote control adapter

NOTE

NPTF, also referred to as 'Dryseal' thread, is designed to provide a more leak-free seal without the use of PTFE tape or other sealant compound. NPTF threads are interchangeable with NPT threads and are standard on all Cash Valve products.